

Pata-Gun

Rotating shock wave nozzle • Pata-Gun
Perfect for Dewatering, Deoiling etc



What is Pata-Gun ?

Air jet mouth rotates with high speed.
The rotation leads intermittent air extensively
You can do dewatering and removing
of dust more efficiently than the conventional Air-gun
You can reduce treating time and save Air-consumption.



Example of application

Dewatering,
for dual lattice of reusable
shipping carton

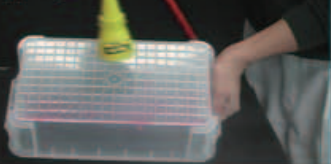

Deoiling
of metal machined parts



Most proper for treating work with roughness

Removing of filing powder
of plastic forming part

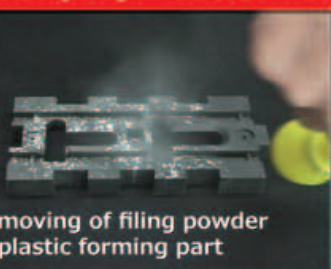

Dewatering of tray
for semi-conductor
(Line is fixed)



Simple installation

Installation with the conventional Gun



Remove point nozzle of Air-Gun

Change it to Pata-Gun



Gun-Point connection should be 1/8" thread.
Otherwise the installation is not possible.

Moving picture
available
www.daico-t.com

Patent

4427033/4427093

Model SPG-40 · 40G

Model: SPG-40 (Unit Type)



Connection: 1/8" G thread Weight: 107g

Size

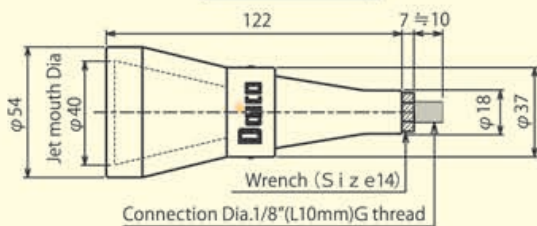

Model :SPG-40G (with Air-Gun)



Connection: one touch coupler (plug 1/4") Weight 315g

Material

- Outer Case → POM resin (Polyacetal)
- Taper wheel → POM resin (Polyacetal)
- Bearing → SUJ2 (steel*Grease enclosed)
- Nozzle Tube → Soft urethane
- Connection → BS (Nickel plated)
- Jet mouth Dia. → 40 φ

Model	Air Flow	Usable Fluid	※Air Pressure		Temperature	Weight	Using flow volume
			Air-gun	Fixed piping			
SPG-40型	100~110NL/min.	Air, Inert gas	0.4~0.45Mpa	0.3~0.35Mpa	10~40°C	(unit type) 107g	Air Volume 100NL/min (0.4MPa)

※Air pressure should be pressure during using air.

Model SPG-25 · 25G

Model: SPG-25 (Unit type)



Connection: 1/8" G thread Weight: 113g

Size

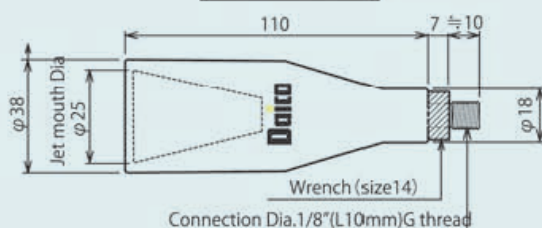

Model SPG-25G (with Air-Gun)

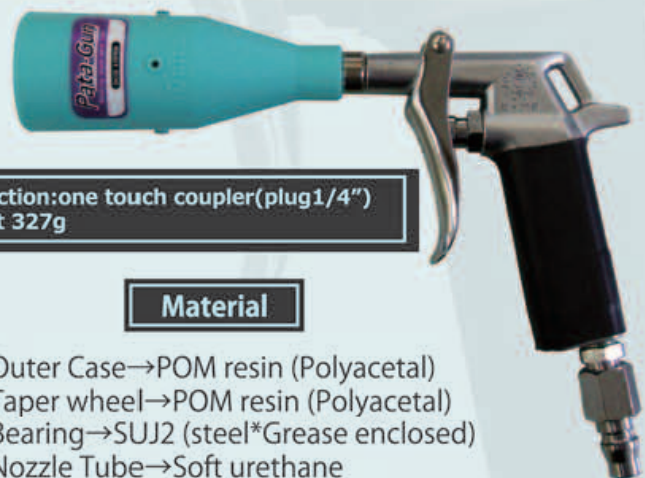

Connection: one touch coupler (plug 1/4") Weight 327g

Material

- Outer Case → POM resin (Polyacetal)
- Taper wheel → POM resin (Polyacetal)
- Bearing → SUJ2 (steel*Grease enclosed)
- Nozzle Tube → Soft urethane
- Connection → BS (Nickel plated)
- Jet mouth Dia. → 25 φ

Model	Air Flow	Usable Fluid	※Air Pressure		Temperature	Weight	Using flow volume
			Air-gun	Fixed piping			
SPG-25型	100~115NL/min.	Air, Inert gas	0.4~0.5Mpa	0.35~0.45Mpa	10~40°C	(unit type) 113g	Air Volume 100NL/min (0.4MPa)

※Air pressure should be pressure during using air.

>> Movement explanation of Pata-Gun(at start of shock wave)

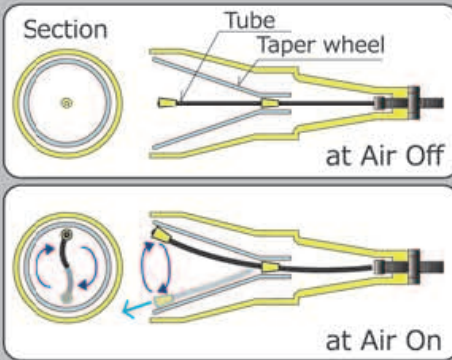

When you feed air, Tube starts to move by the pressure and to rotate along inside wall of taper wheel. When you touch jetting mouth of pata-gun by your hand, you feel intermittent hitting of air. It is Shock wave.

Shock wave generated by rotation of tube generates air impact power of same rotation as tube rotation. (SPG series: 20 rotations/sec or more)

Taper wheel (white cover) is a part which makes synchronous rotation with nozzle tube. By this synchronous rotation, you can reduce frictional resistance and protect the generation of dust and consumption.

>>What is difference between Pata-Gun and conventional Air-Gun

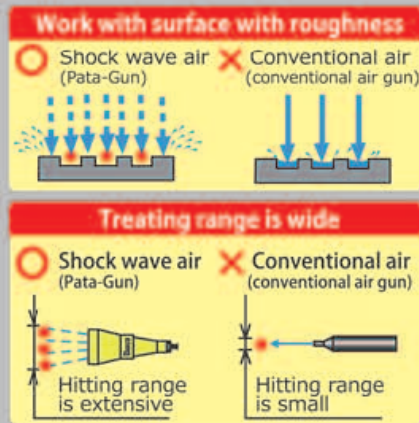

Pata-gun repeats air impact power due to effect of rotation shock wave nozzle and as a result you can hit and get out the remaining water in dent.

In case of conventional air gun, it pushes only by air and can not jump difference in level and as a result the water remains in dent.

In you use it with same pressure and same flow volume, pata-gun can treat more wide range by effect of rotating shock wave nozzle pata-gun shock wave.

Pata gun is air nozzle for saving energy

>> What is difference between SPG-40 and SPG-25 ?



SPG-40

It should be proper when you want to treat wide range



SPG-25

It should be proper when you want to hit small place at pin-point and to treat narrow range.

>> What is range of shock wave hitted ?

SPG-25 and **SPG-40**

Relation between distance and strength of shock wave
Relation between distance and Jet effective Dia

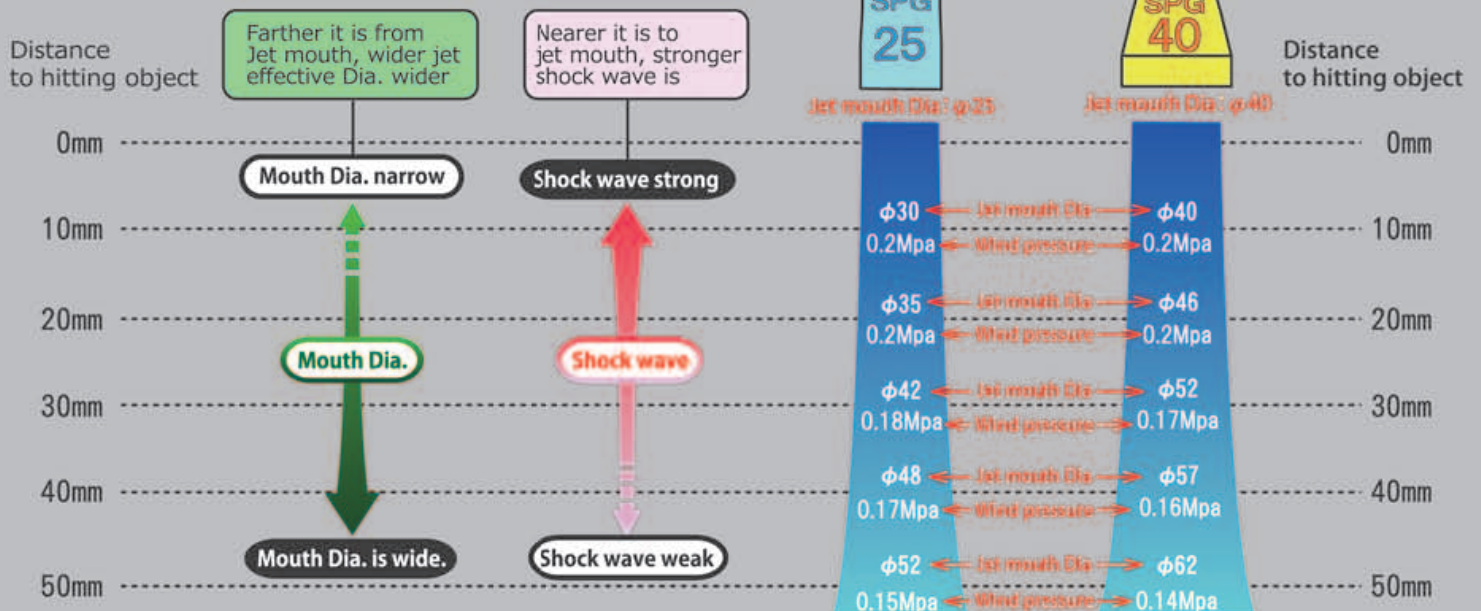

※ It is our measuring value at blowing pressure of 0.4Mpa. Different value could be measured depending on environment to be used

NEW

PGO-91

Shock wave Nozzle·Pata-Gun
(for Air Compressor)**Pata-Gun**

Impact wave realizes increasing of work efficiency and energy-saving at same time.

Patent
5208191

Air jet mouth

(Amplitude working part)

←Air waving image spread over wide range

At fluid spraying part, intermittent impact wave is available over wide range due to high speed amplitude. As a result you can remove water and dust save air consumption more efficiently than conventional air blow gun and you can reduce the process time.

Model: PGO-91 (Unit Type)

Connection: 1/8" G thread
Weight: 72g

Model: PGO-91G (with Air-Gun)

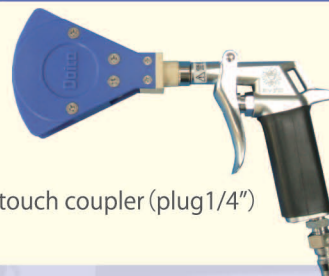
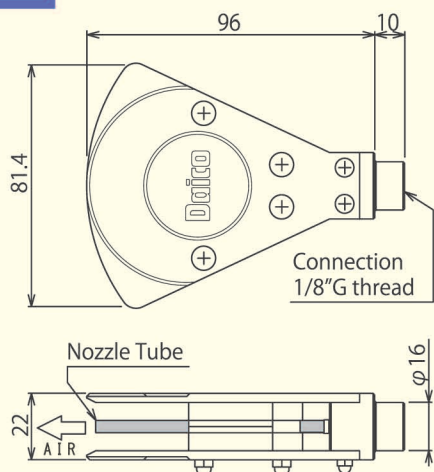
Connection: one touch coupler (plug 1/4")
weight: 300g**Size****Material**Outer Case : POM resin (Polyacetal)
Nozzle Tube : Soft urethane
Screw part : SUS304

Air Flow	Usable Fluid	Air Pressure		temperature
90~120 NL/min.	Air, Inert gas	Air-Gun 0.4~0.45MPa.	Fixed piping 0.35~0.4MPa.	10~40°C

※ In order to improve performance, product specifications may be changed.

The reason why Pata Gun is called as "Eco Gun"

Energy saving data for Model SPG-40 by our comparison.

[The principle of Pata Gun]

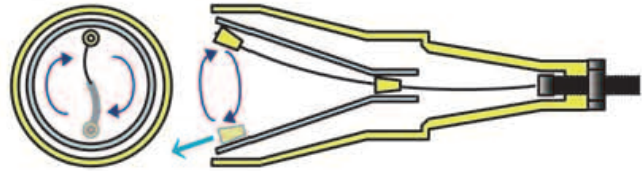

Pata Gun is the products which expand the range of airblow of jetting exit due to high speed rotation along inside of cover. the range is expanded, but the effect can not be reduced. Air can be increased rather due to impact shock wave.

The difference of effective range from conventional air gun

Although Air Volume is same 4:1.

(comparison of dewatering for printing screen)

Saving of JY200,000.-By Pata Gun 1 pc. Only Electric charge 1/3 or less per year.

Pata Gun SPG-40

Air consumption 100L/min.
at Air pressure 0.4MPa.



In Dewatering
of 60mm range
Air consumption:
100L/min.

Necessary capacity
of compressor:
1.5 KW

Electric Charge/year:
JY75,000.-

Effective range Approx.
60mm

As for life of Pata Gun, we have performance of 3,000 hours or more and it is still under progress as of April 2009. The life is up to the using condition and environment. Anyway try 1 pc.

Conventional airgun 3Dia

Air consumption 100L/min.
at Air pressure 0.4MPa.



4 air guns are necessary
for dewatering of 60mm range
Air consumption:
400L/min.

Necessary capacity
of compressor:
5.5 KW

Electric Charge/year:
JY275,000.-

Effective range Approx.
15mm

Calculation condition of Electric Charge: JY20.-/kWh, 10hours/day 250days/year. Compressor is upto modand hence we calculate it safety wise.

The difference of Airblow of conveyer with 300mm width compared with conventional air gun

Electric charge 1/4! You save JY825,000.-

Pata Gun SPG-40

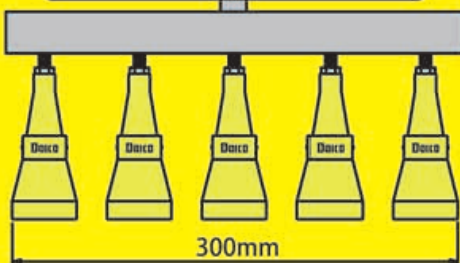

SPG-40 x 5 pcs

Air Consumption >>> **500L/min.**
(0.4MPa.)

Necessary capacity
of Compressor >>> **5.5KW**

Electric Charge >> **JY275,000.-**

Conventional resin nozzle

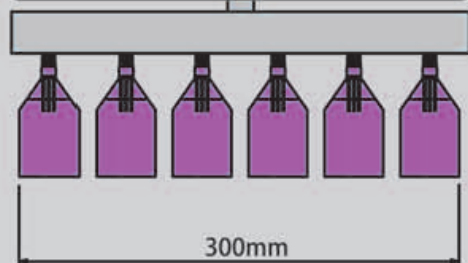

Resin Nozzle x 6 pcs

3000L/min. <<< Air Consumption
(0.4MPa.)

22KW <<< Necessary capacity
of Compressor

JY1,100,000.- << Electric Charge

Important

【Know How how to use Pata-gun】

Use it better and work more ef ficiently

Good and bad example when you do dewatering with Pata-Gun

←Shock wave air ←Movement of water

○ Correct way of using

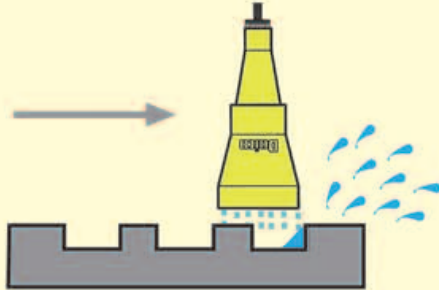

× Wrong way of using

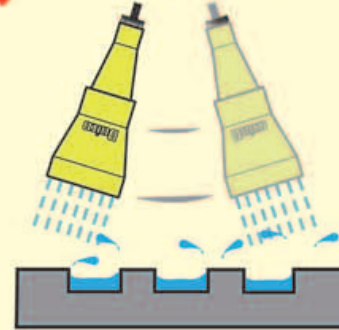

- ① Never swing Pata-Gun, otherwise the effect is going down
- ② Shift it horizontally and slowly to constant direction without swinging
- ③ Recommendation distance between Pata-Gun and the object will be 10mm ~ 20mm (longest 80mm)

【Application of Pata-Gun SPG series supplied】

>> General field

- Cleaning of various filter materials
- Cleaning of recycle commodity
- Dewatering of printing screen after the washing process
- Cleaning of Aluminium Fin of radiator and heat exchanger
- Dewatering of surface roughness for dual lattice of reusable shipping carton
- Agitation drying of granular resin material
- Dewatering of filter etc for air conditioner after the cleaning
- Cleaning of car seats
- Cleaning of machine tool
- Dewatering of resin products before the painting
- Others

>> Electronics field

- Dewatering of transfer tray of semiconductor after the cleaning
- Removal of dust and particles for mount board.
- Prevention of solder drooping of circuit board after taking it out from solder tank
- Others

>> Automobile field

- Removal of sand in foundry factory
- Deoiling and Dewatering of Diecasting products
- Deoiling and Dewatering after drilling and tapping of Engine etc
- Removal of excessive anti-rust preparations for preservation and drawing oil after press forming process
- De-burring afer metal machining process
- De-burring of resin forming products like head light parts, instrument panel etc
- Removal of grinding powder for resin forming products like head light parts, instrument panel etc
- Dewatering of resin forming products like head light parts, instrument panel etc

>> Food Field

- Dewatering of concavity for three-dimensional packing of food
- Dewatering of grip part of mineral water bottle
- Dewatering of food before the date priting
- Removal and Dewatering of dirt of chain/net-conveyer
- Throwing of dust of working clothes
- Dewatering of food tray after the cleaning
- Others

※ Specification is subject to change without notice due to improvement of quality

【Spare Parts】

There are thefollowing spare parts for 2 types of SPG type.

PGO - 91 has no spare parts.

SPG-40/40G Spare Tube



SPG-25/25G Spare Tube



SPG-40/40G Spare Corn



SPG-25/25G Spare Corn

