

Our Cable Solutions for Factory Automation

Our Cable Solutions
for Factory Automation



Our robot cables and movable products are provided with excellent characteristics for supporting factory automation.

Articulated robot



High-flexure, high-speed interface cables

(Gig-E, Camera Link, USB3, 1394b, CoaXPress)

- Flexible
- Excellent flexural durability
- Stable transmission performance

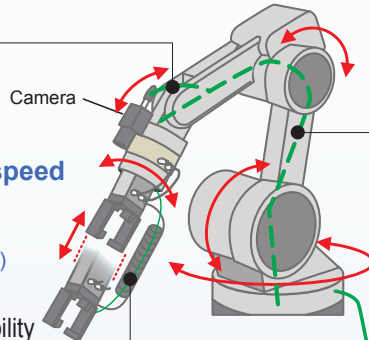

High-flexure cables (ORP-SL cables)

- Thin
- Flexible
- Excellent durability (flexing/twisting/sliding)



Coil cords

- Ideal for stretching section
- Excellent durability (bending/twisting/stretching)

Controller



High-speed interface composite cables

- Excellent flexibility
- Excellent flexural durability
- We provide composite products with universal custom designs (high-speed transmission/power supply/controls)

Cartesian coordinate robot



Parallel cables

(VEYOR Cables)

- Ideal for expanding and contracting sections
- Custom production for small lots
- Complete control for branching processing as well

Ex: Carrier less

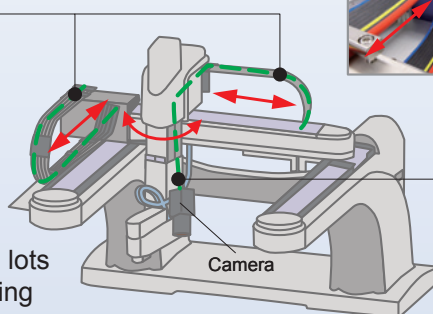
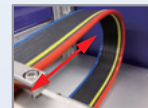

High-flexure, high-speed interface cables

(Gig-E, Camera Link, USB3, 1394b, CoaXPress)

- Flexible
- Excellent flexural durability
- Stable transmission performance

Industrial microscope

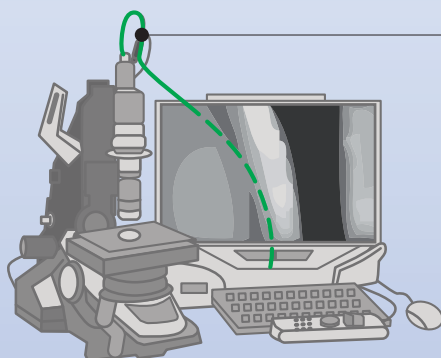

High-speed interface cables

(Gig-E, Camera Link, USB3, 1394b, CoaXPress)

- Flexible
- Excellent flexural durability
- Stable transmission performance

Factory automation

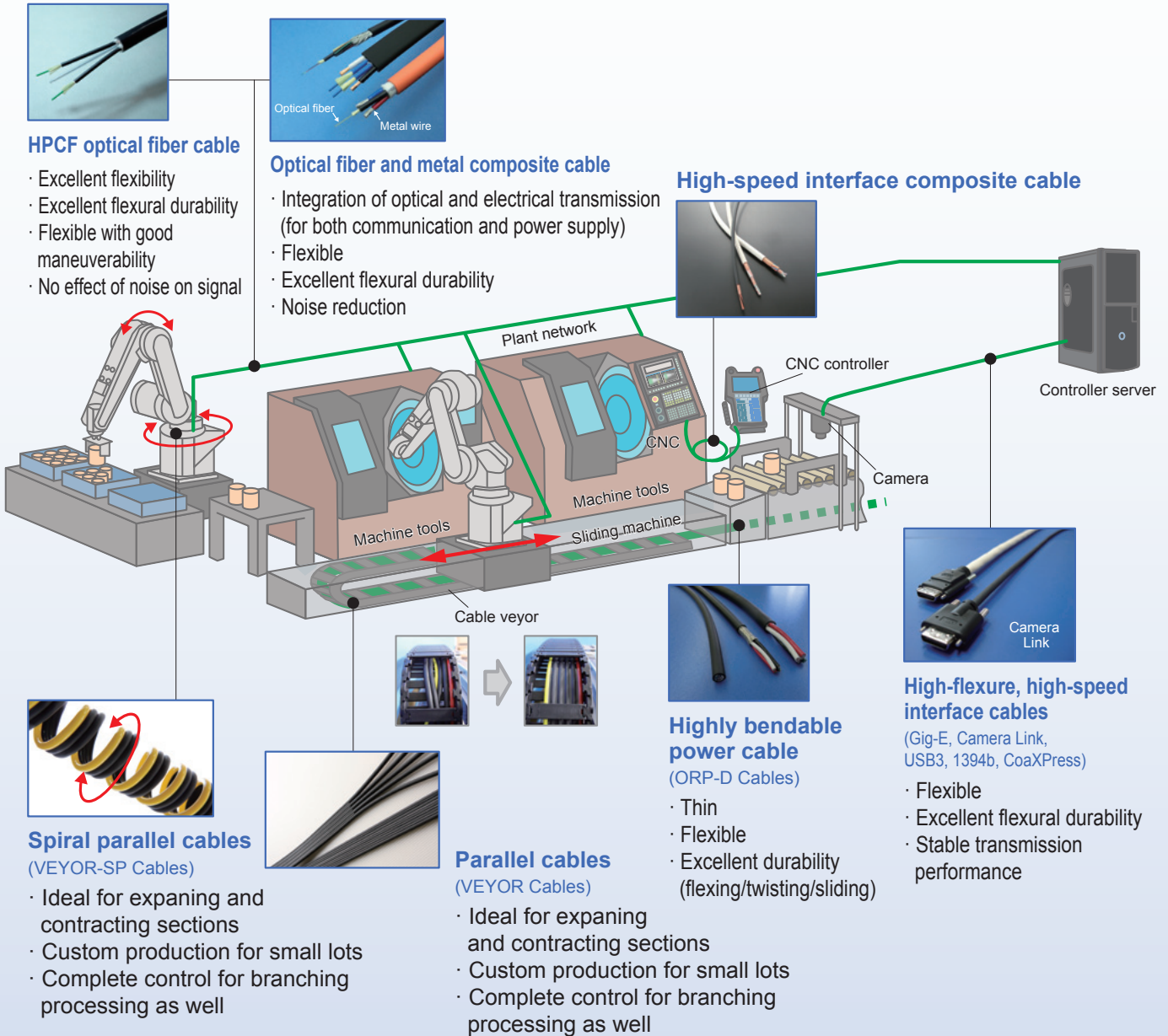

Industrial endoscope

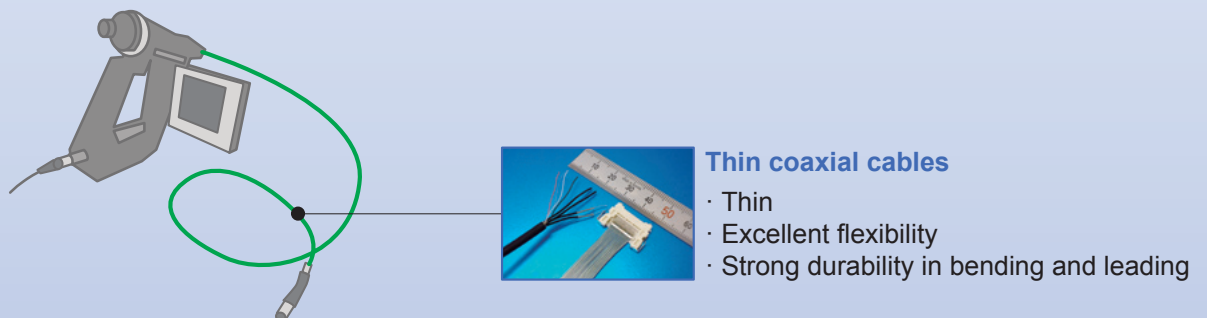

Cable products

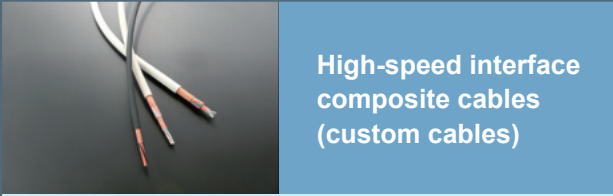

High-speed interface composite cables (custom cables)

We offer custom-made interface cables best matched to the equipment. We can meet diverse demands such as high-speed transmission, power supply, equipment control, bending performance, and flexibility. This is ideal for wiring used inside and outside of C-arm X-ray equipment and between FPD and X-ray image processing equipment.

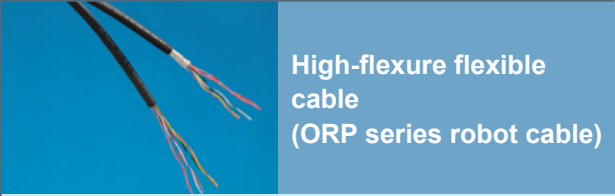

High-flexure flexible cable (ORP series robot cable)

Adding to the ingenuity of our sliding, flame-retardant, elastomeric material and structure, we have created small-diameter, highly flexible products at low prices. This product can handle various types of movements such as bending, sliding, and twisting. This is ideal for the movable control wires of C-arm X-ray equipment.



Flat cables (VEYOR CABLE)

A flat cable for which the cable has been bond processed. This is effective in preventing the cables from entangling with each other in the compact and movable portion of the housing of the equipment. Order-made products can be manufactured starting from a single unit. This is ideal for the upper and lower movable parts of the chest X-ray equipment.



Coil cords (VEYOR-SP CABLE)

By processing the movable cable into a spiral cord, the range of applications increases because it allows for not only expansion and contraction but also twisting and bending. We can also process the VEYOR-CABLE into a coil cord (VEYOR-SP CABLE). This is perfect for products such as AED electrode cables.

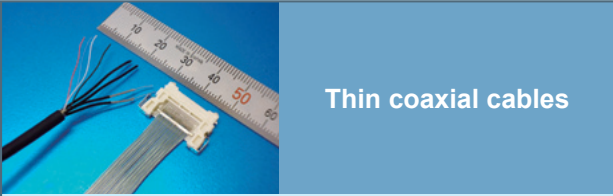

Thin coaxial cables

This superior coaxial cable is excellent for wiring in narrow spaces such as in thin tube because of its small diameter, flexibility, and high-speed transmission performance. It can also be used to combine wiring for power supply and controls. It is also ideal for endoscopic probe wiring.

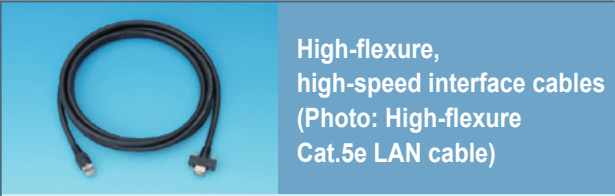

High-flexure, high-speed interface cables (Photo: High-flexure Cat.5e LAN cable)

We also have a line-up of superior high-flex, noise-resistant IF cables with screw connectors (GigE, USB3, 1394B, etc.). These are ideal movable wiring in products such as surgical microscope cameras.

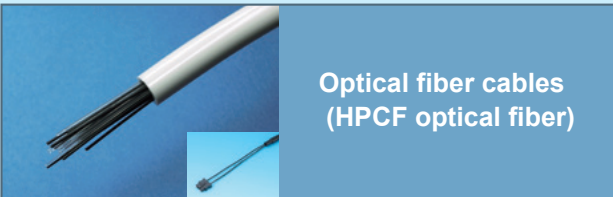

Optical fiber cables (HPCF optical fiber)

The HPCF optical fiber cables of Oki Electric Cable are characterized by both high-performance all-quartz optical fibers and easy-to-handle plastic fibers. This is excellent for wiring in MRIs. Integrating optical fiber and metal wires, optical-metal composite cables with power supply capability are also possible.

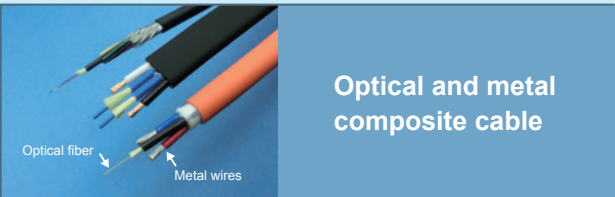

Optical and metal composite cable

These are optical and metal composite cables in which fiber optics and power supply wire have been cabled together as one unit. A single cable is able to provide high-speed stable optical transmission as well as power supply to the equipment. Because these are manufactured as custom-made cables, we can customize them from round to flat according to your applications.

Our Cable Solutions for Factory Automation

Specialized technology

1. *Movable cable technology with excellent durability*

Through developing FA cables for robotics, we have accumulated the know-how for designing strong bendable cables.

2. *High-speed transmission technology*

Utilizing electromagnetic field simulation technology has allowed us to design optimal cables for digital transmission.

3. *Customized design technology*

We have accumulated experience and track record in specialized cables for robotics and industrial equipment.

E.g., special design that integrates different wire types
With a complex combination of metals and optics and communications, power supply, and control systems, we have achieved both high flexibility and high-speed transmission performance.

E.g., improvements aimed enhancing thinness, flexibility, and bending durability (cable customization)

Robot Cable Evaluation test

Oki Electric Cable achieved "Durability Test" considering such tough situation and keep high standard quality standard

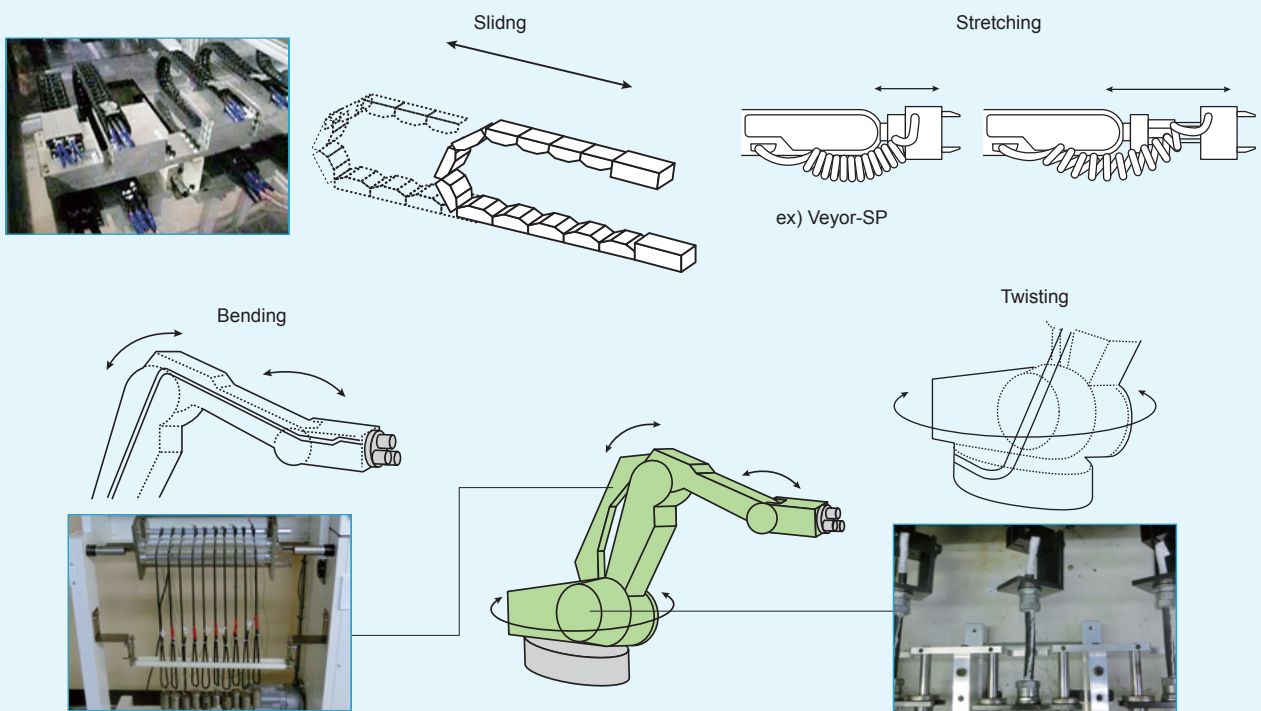

Domestic/international locations

Head office

2-12-8 Shimokodanaka, Nakahara-ku, Kawasaki-shi, 211-8585 Japan TEL +81-44-766-3171

Sales offices

Sendai sales office

Grand Shario Bldg., 3-10 Futsukamachi, Aoba-ku, Sendai-shi, 980-0802 Japan

TEL +81-22-266-0855

Gunma sales office

3344-1 Sakaiyoku, Isesaki-shi, Gunma-ken 370-0105 Japan TEL +81-270-76-4300

Nagano sales office

2-10-1 Osachigoshō, Okaya-shi, Nagano-ken 394-8686 Japan TEL +81-266-27-1597

Nagoya sales office

Daiei Bldg., 1-11-20 Nishiki, Naka-ku, Nagoya-shi, 460-0003 Japan TEL +81-52-201-2130

Osaka sales office

Oak Esaka Bldg., 10-28 Hiroshibacho, Suita-shi, Osaka-fu 564-0052 Japan TEL +81-6-6337-2681

Fukuoka sales office

Kyushu Branch, Oki Wintech Co., Ltd., Shin KBC Bldg., 1-1-35 Nagahama, Chuo-ku, Fukuoka-shi, 810-0072 Japan TEL +81-92-738-1685

Factories

Gunma Factory

3344-1 Sakaiyoku, Isesaki-shi, Gunma-ken 370-0105 Japan TEL +81-270-76-4311

Okaya Factory

2-10-1 Osachigoshō, Okaya-shi, Nagano-ken 394-8686 Japan TEL +81-266-27-2255

Domestic subsidiaries

Oki Electric Cable Wire Harness Co., Ltd.

3344-1 Sakaiyoku, Isesaki-shi, Gunma-ken 370-0105 Japan TEL +81-270-76-7865

Oki Electric Cable Service Co., Ltd.

2-10-1 Osachigoshō, Okaya-shi, Nagano-ken 394-8686 Japan TEL +81-266-27-0433

Mogami Wire & Cable Corp.

469 Souga, Shiojiri-shi, Nagano-ken 399-6461 Japan TEL +81-263-52-0131

International subsidiaries

Oki Electric Cable Changshu Co., Ltd.

19th Xihuantu Zhangqiao Xinzhuang town, Changshu China TEL +86-512-5299-2059



Head office



Okaya Factory



Gunma Factory

Oki Electric Cable Co., Ltd., has been certified to ISO9001 Quality Management System.

The Gunma Factory and Okaya Factory have ISO14001 environmental management certification.

Due to the printing specifications, the colors of products may differ slightly from those of the actual products.

OKI

<http://www.okidensen.co.jp/en/>

TEL: +81-44-754-4369 E-mail: oec-ovssales@oki.com



VOC
FREE T&K